

Forme · Formes · Shapes · Formen · Formas

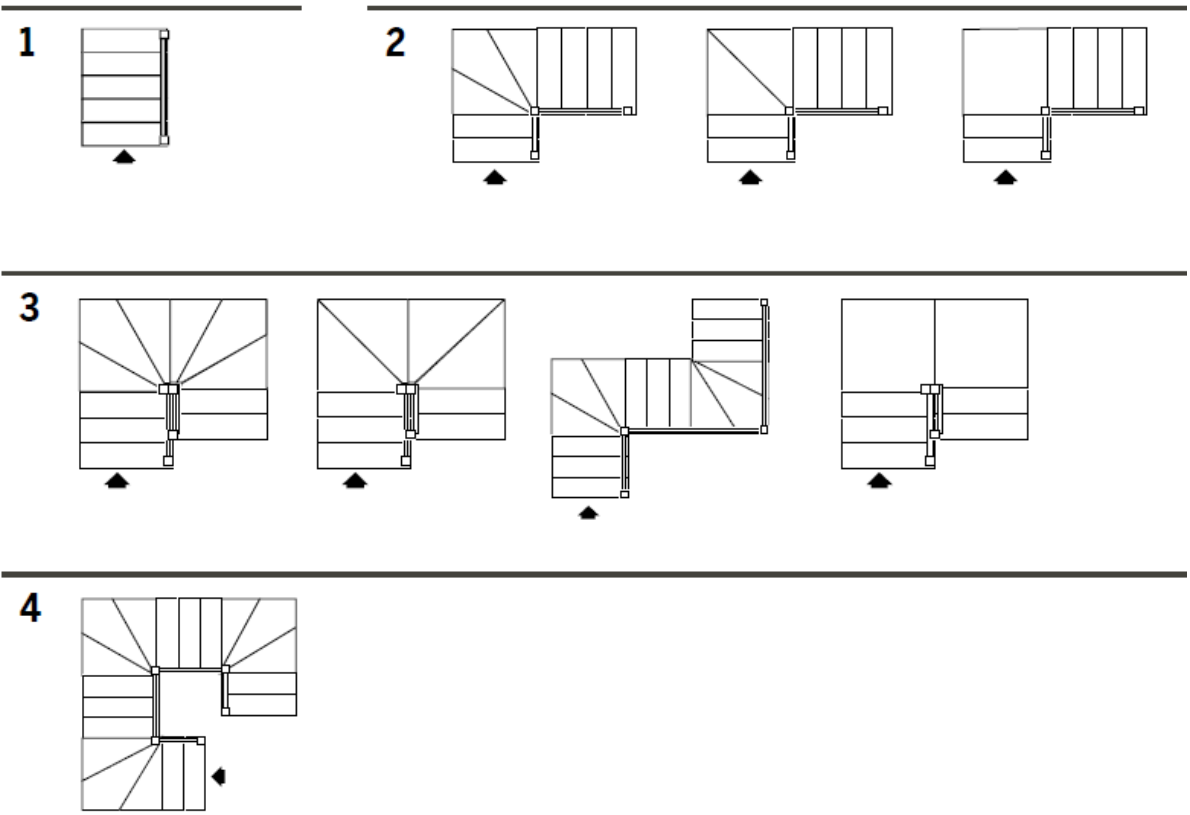

	G10	G11	G12	G13	G14	G15	G16	G17
h	h	h	h	h	h	h	h	h
	1870	2040	2210	2380	2550	2720	2890	3060
	2310	2520	2730	2940	3150	3360	3570	3780



REXAL RX2

LE FORME DELLA STRUTTURA

The shapes of the structure

Les formes de la structure

Die Formen der Struktur

Las formas de la estructura

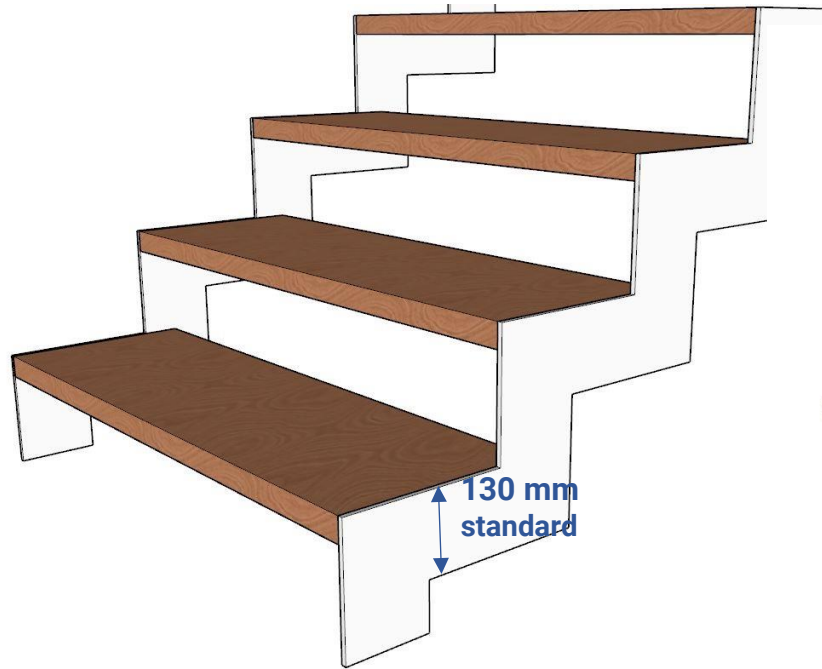

Z
(standard)

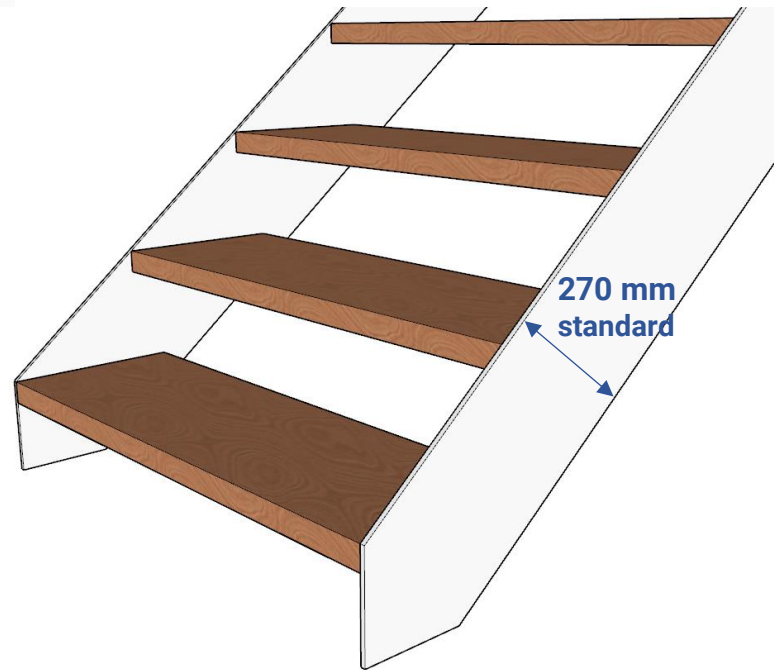

L
(optional)

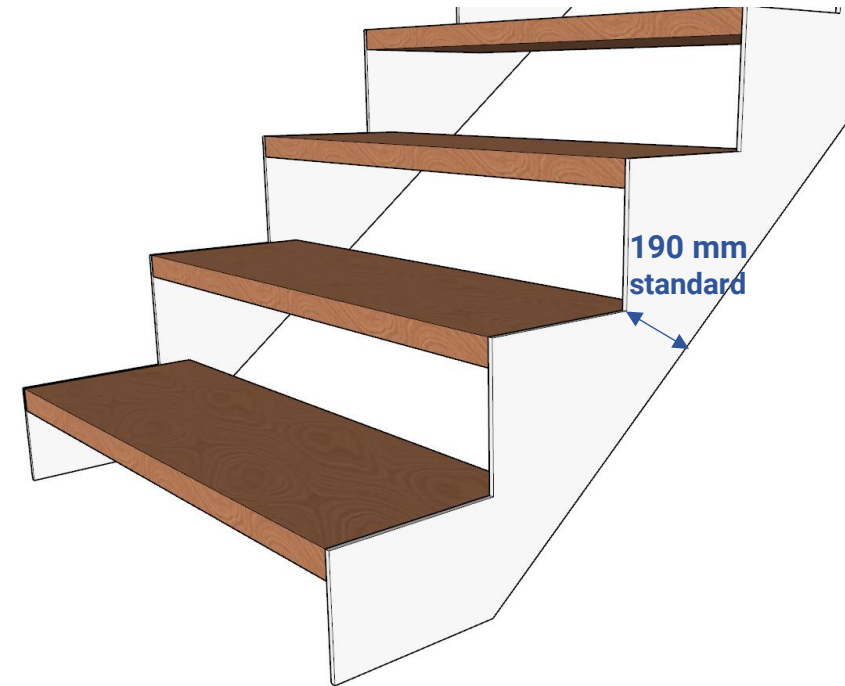

ZL
(optional)

Caratteristiche tecniche

Technical specifications
Spécifications techniques
Technische Daten
Características técnicas

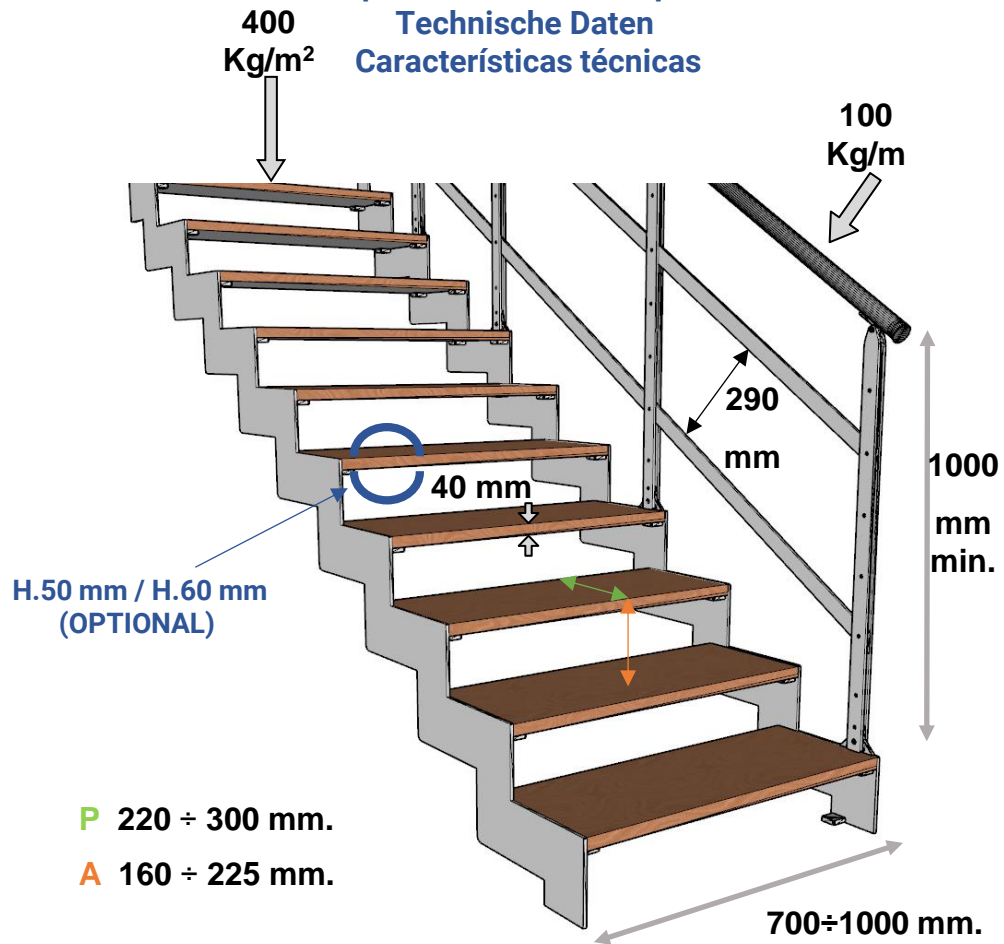

Tipologie di legno disponibili

Type of Wood
Type de bois
Holzart
Tipo de madera



Faggio
Beech
Hêtre
Buche
Haya



Rovere
Oak
Chêne
Eiche
Roble

Calcolo passaggio utile

Useful passage - passage utile
-nützliche Passage - Pasaje útil

$$L - R (26,50 \text{ mm}) = P$$

RINGHIERA TOTALE
TOTAL BANISTER
GARDE-CORPS TOTAL
GELÄNDER
BARANDILLA
26,50 mm

R

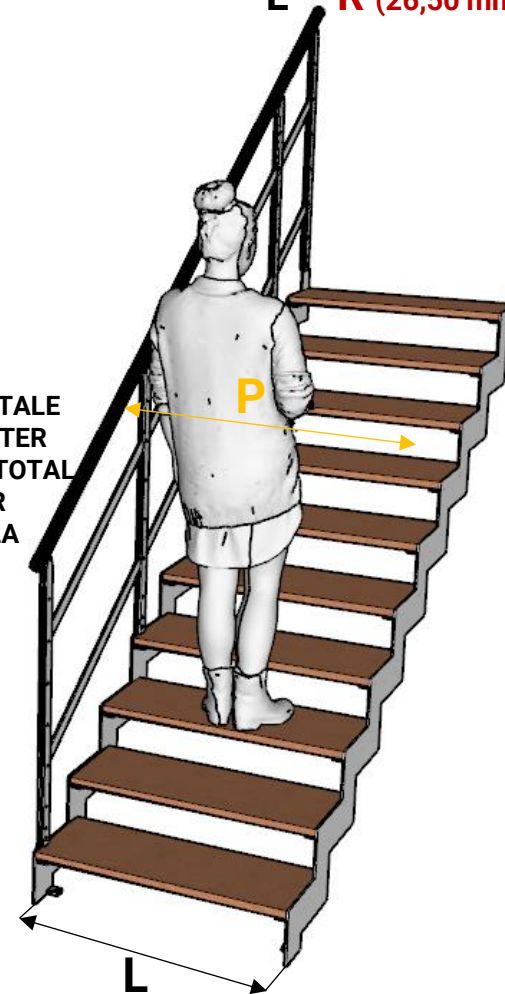

Caratteristiche tecniche

Technical specifications
 Spécifications techniques
 Technische Daten
 Características técnicas

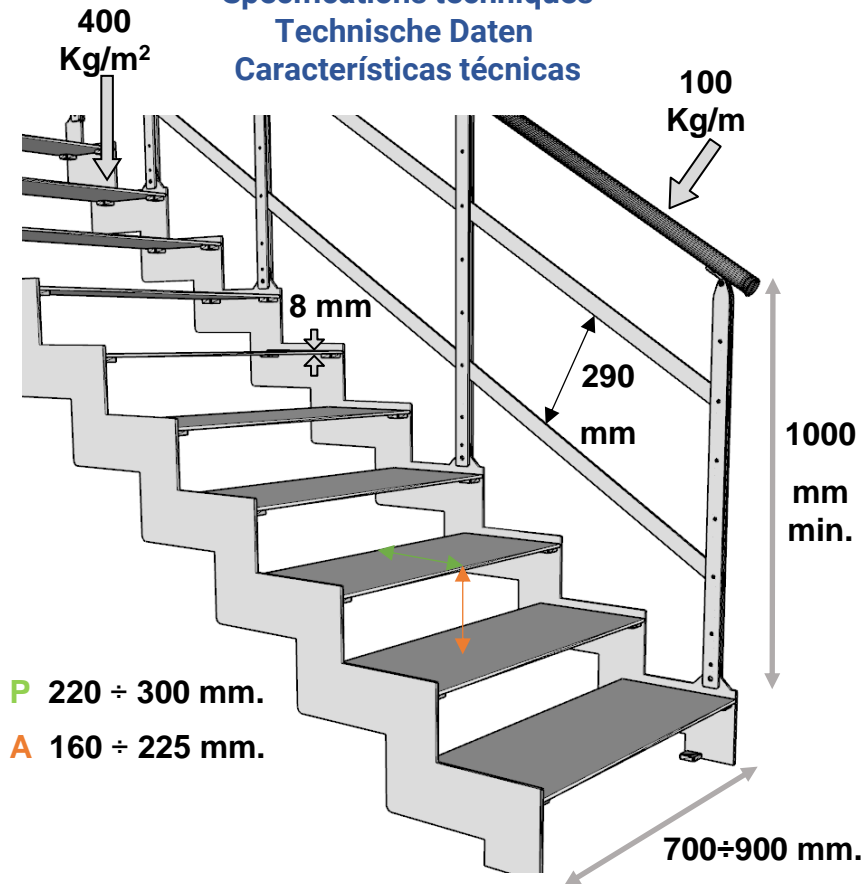

Calcolo passaggio utile

Useful passage - passage utile
 -nützliche Passage - Pasaje útil

$$L - R (26,50 \text{ mm}) = P$$

RINGHIERA TOTALE
 TOTAL BANISTER
 GARDE-CORPS TOTAL
 GELÄNDER
 BARANDILLA
 26,50 mm

R

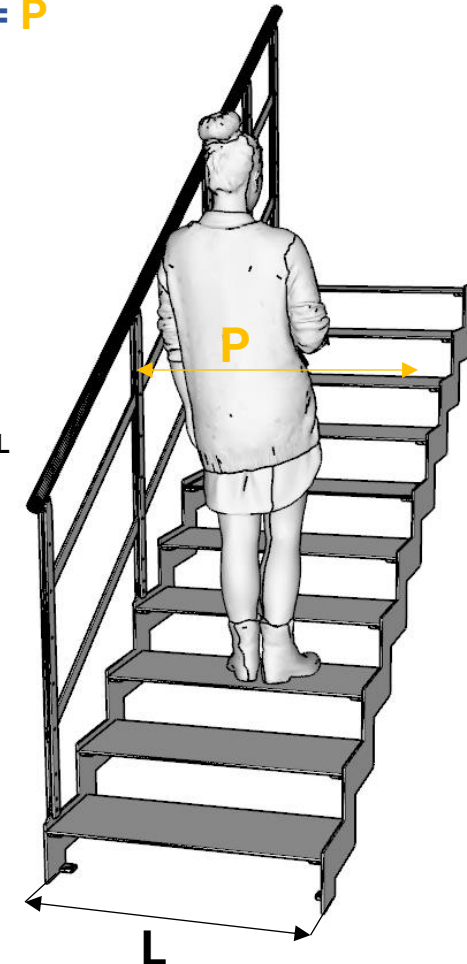

ARRIVO CON ALZATA
ARRIVAL WITH RISER
ARRIVÉ AVEC HAUTEUR
ANKUNFT MIT STEIGUNG
LLEGADA CON CONTRAHUELLA

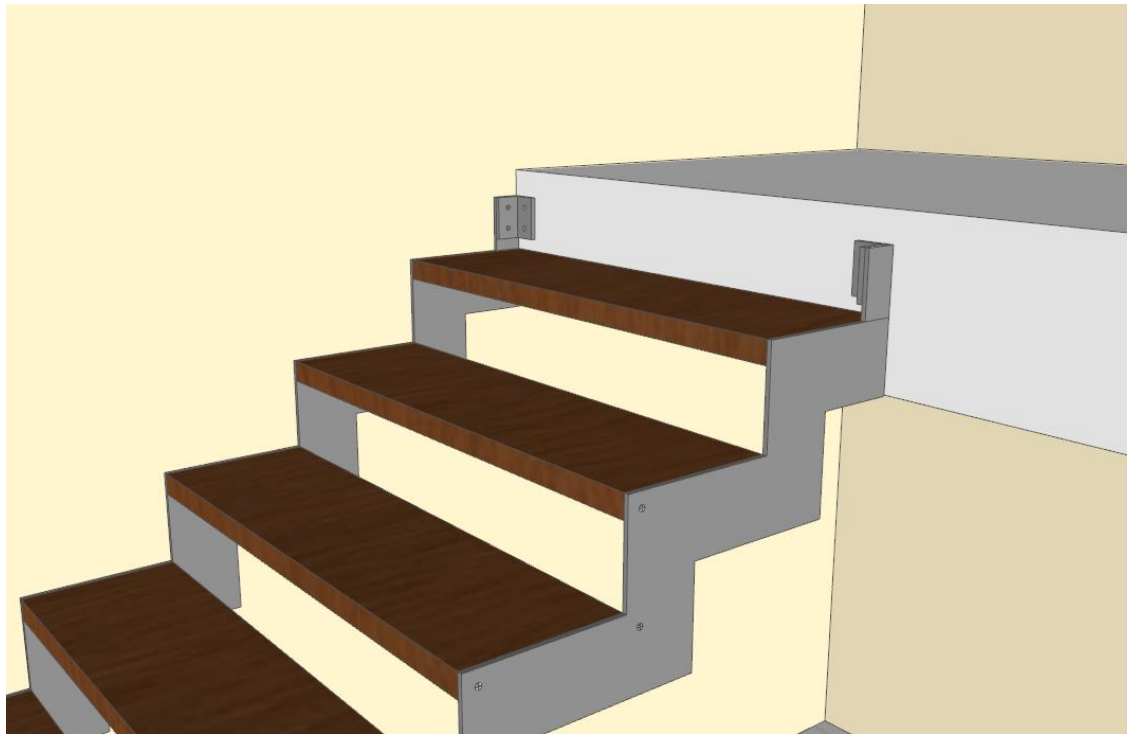

ARRIVO PARI PAVIMENTO
ARRIVAL AT SAME FLOOR LEVEL
ARRIVÉE AU MÊME NIVEAU DU SOL
ERREICHUNG GLEICHEN NIVEAU DES BODENS
LLEGADA MISMO NIVEL QUE EL SUELO

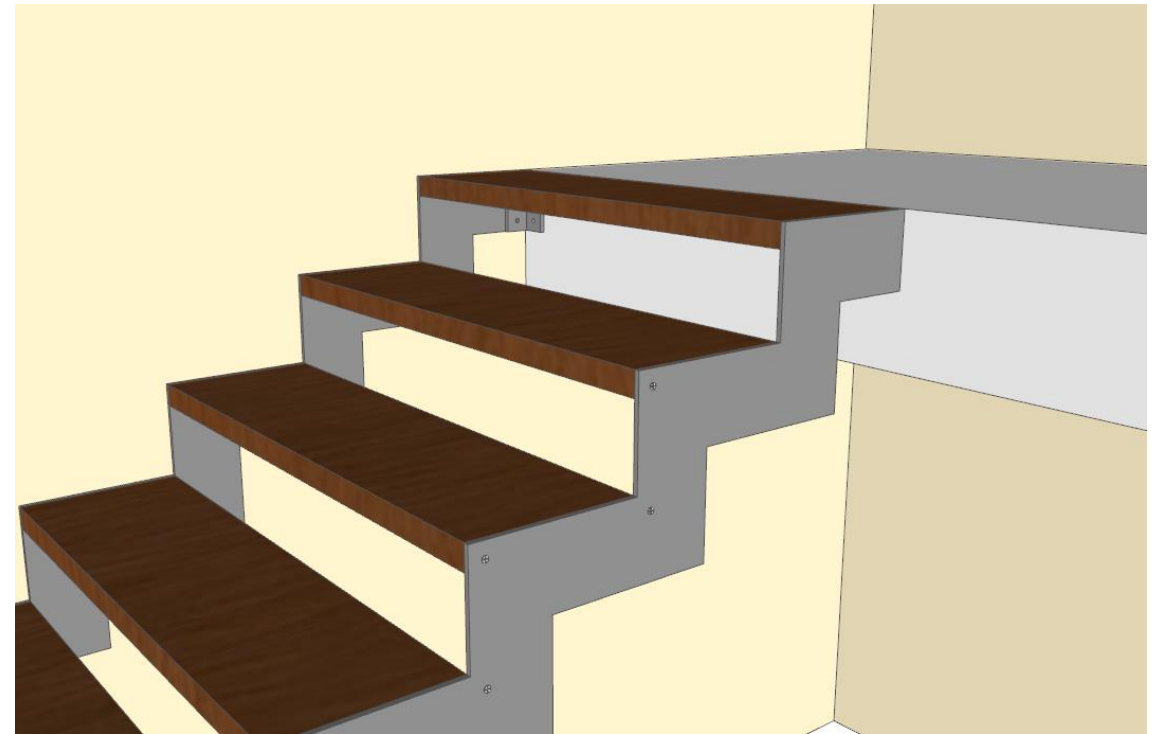

PARTENZA DA PAVIMENTO

FLOOR DEPARTURE - DÉPART DU SOL - ABGANG VOM
BODEN - SALIDA DESDE EL SUELO

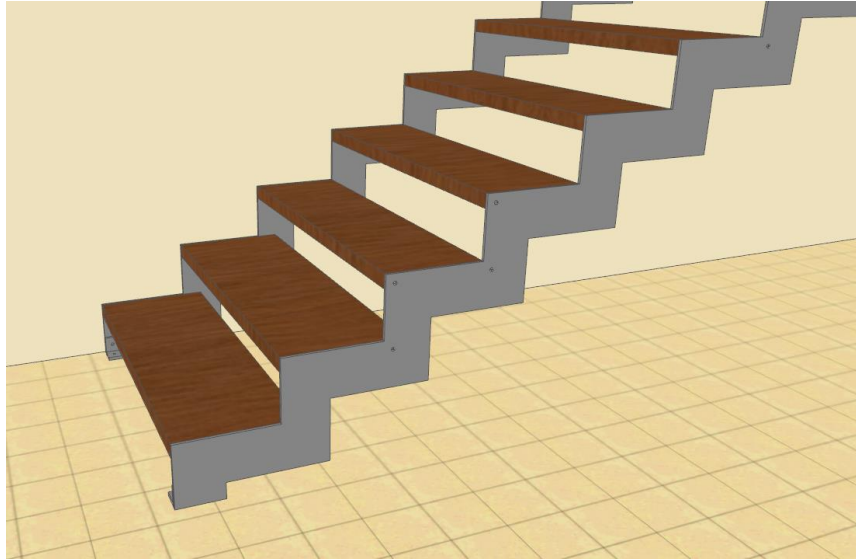

PARTENZA A SBALZO

CANTILEVER DEPARTURE - DÉMARRAGE EN PORTE-À-
FAUX - ÜBERHANGSTART - ARRANQUE EN VOLADIZO

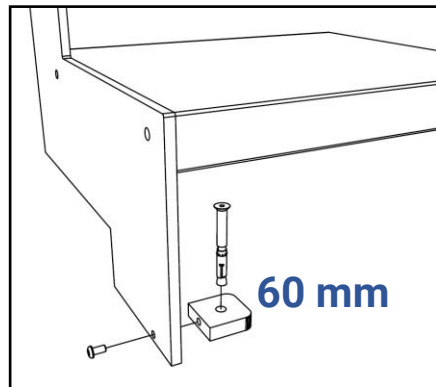
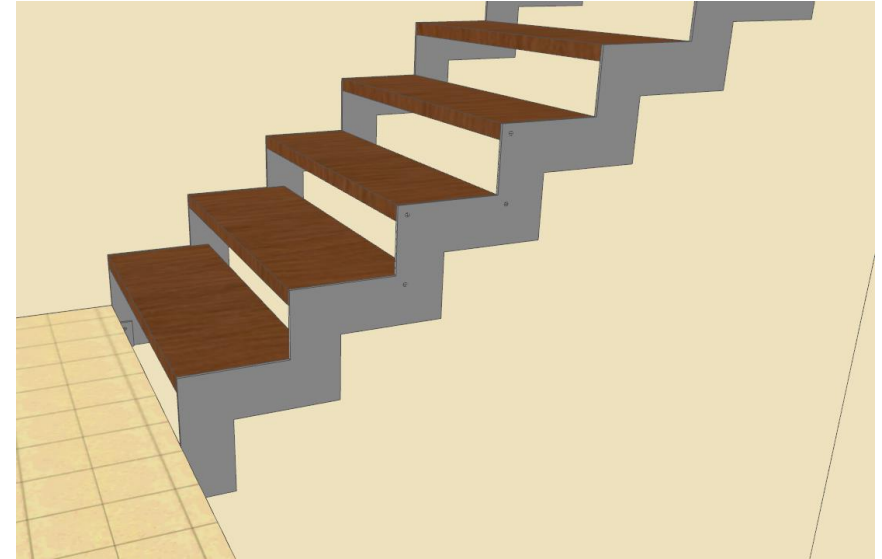

FISSAGGIO A PAVIMENTO

FLOOR FIXING
FIXATION AU SOL
BODENBEFESTIGUNG
FIJACIÓN DEL SUELO

BALAUSTRRE DISPONIBILI

Available Floor Protection Balustrade – Garde-corps étage disponibles –
Schutzgeländer verfügbar -Barandillas disponibles

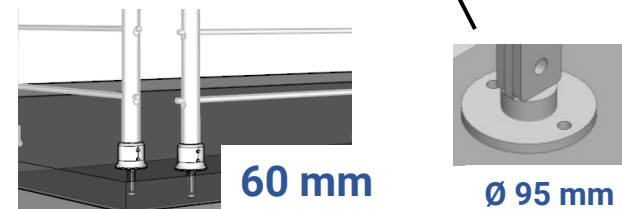
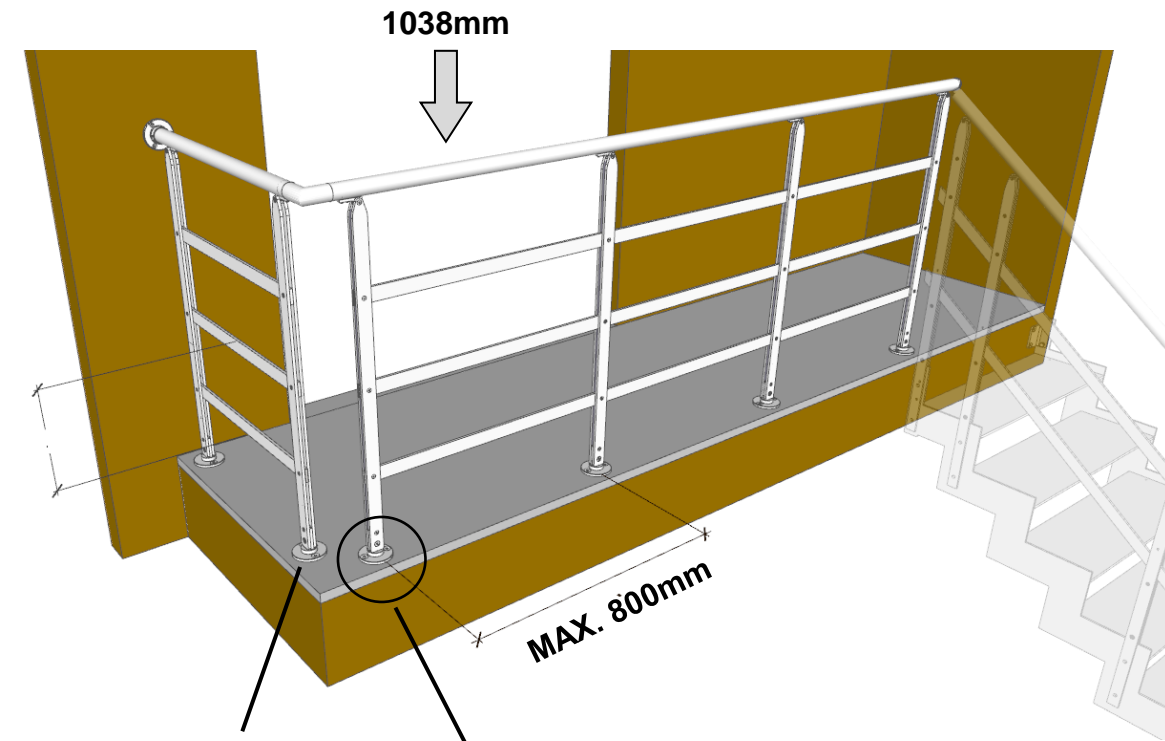

A PAVIMENTO
AT FLOOR
AU SOL
AM BODEM
FIJACIÓN DEL SUELO

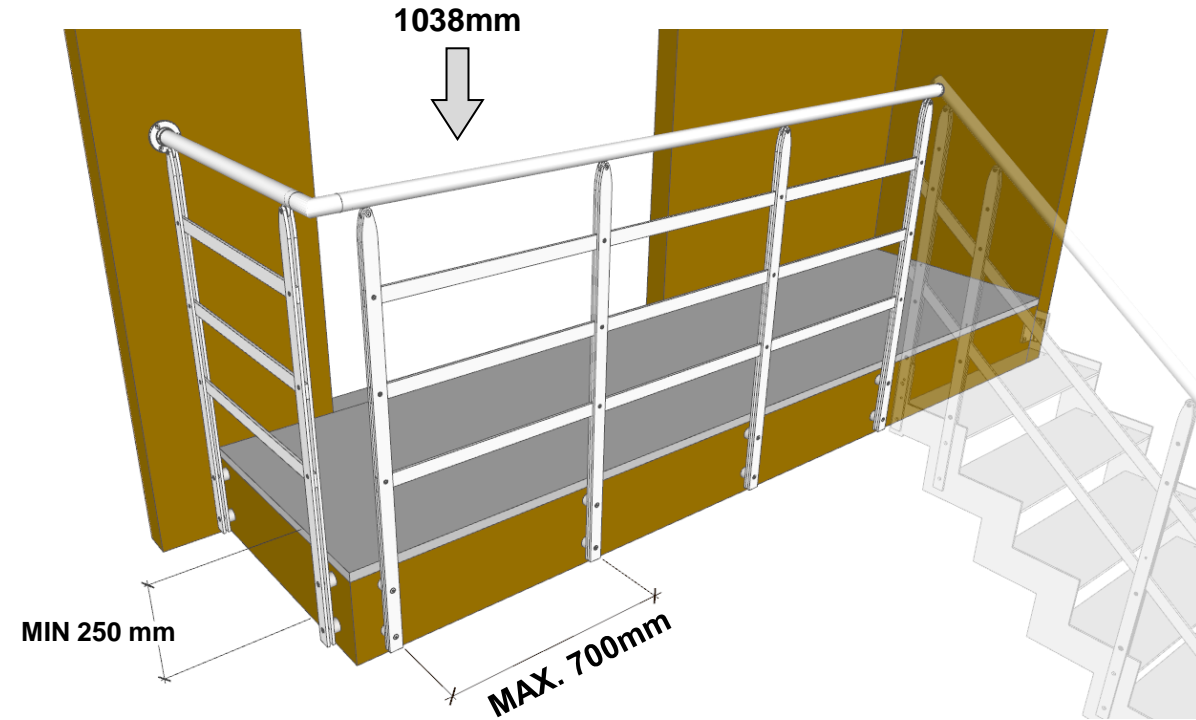

A SOLETTA
EXTERNAL FIXATION AT SLAB
FIXATION EXTERNE À LA DALLE
AUSSENBESTEFUNGUNG DER PLATTE
FIJACIÓN A LOSA EXTERIOR

Corrimano a muro- Wall handrail – Main courante murale - Wandhandlauf - Pasamanos de pared

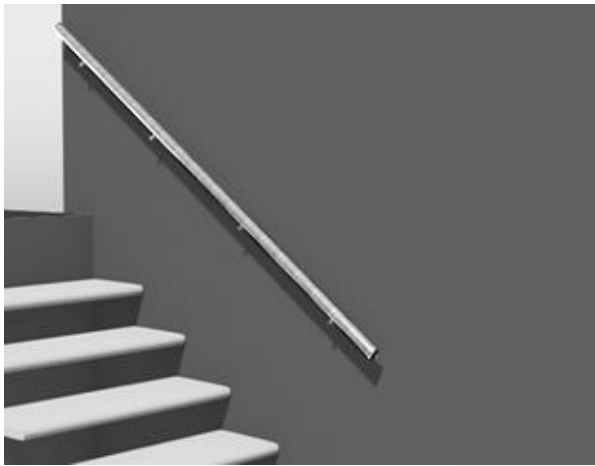

**Gradino in legno – Wooden steps
Marches en bois – Stufenholz - Peldaños de madera**



Alzate chiuse (solo con gradino in legno)

Closed Risers (wooden steps only) – Contremarches (maerhces en bois seulement) - Setzstufen (nur Stufen aus Holz) – Contrahuella cerrada (sólo peldaños de madera)

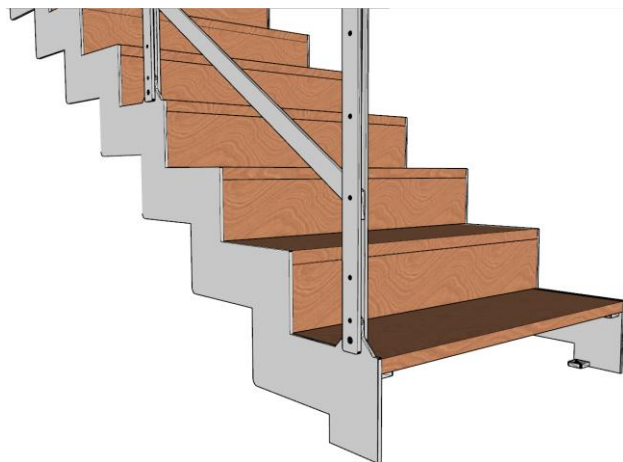

Scala fuori squadra

**Out of square stair - Escalier hors équerre
Unregelmäßige Treppe - Escalera fuera de escuadra**

